

Jesse Auditorium

157 Jesse Hall
Columbia, MO 65211

University Concert Series

University of Missouri
203 S. 9th St.
Columbia, MO 65211

<http://www.concertseries.org/>

Technical Information Package

**Jesse Auditorium
University of Missouri**

Table of Contents

Event Production Services.....	1
General Information.....	3
Technical Staff.....	3
Mailing address.....	3
Local Amenities.....	3
ADA Accessibility.....	3
Emergency Information	3
Travel Directions/Parking	3
Management.....	4
Production Office	4
Crew	4
ADA Accessibility.....	4
Policies	4
Load in Area	4
Carpentry	5
Seating	5
Stage Dimensions.....	5
Stage floor.....	5
House Soft Goods	5
Line Set Data	6
Lighting.....	7
Fixture Inventory	7
Effects	7
Projection Equipment	8
Sound	9
Equipment Inventory	9
Props	11
Wardrobe.....	11
Appendices.....	12
Appendix A: Line Set Schedule.....	13
Appendix B: Lighting Circuit Layout	14
Appendix C: Sound Input Layout.....	15
Appendix D: Seating Chart	16
Appendix E: Auditorium Drawings	17
Appendix F: Auditorium photos.....	22
Appendix G: Driving Directions/ Maps.....	25

**Jesse Auditorium
University of Missouri**

General Information

Staff

<u>Manager</u>	<u>Technical Director</u>	<u>Asst Technical Director</u>
Robert Wells	Chris Cullen	Eddy Bickford
Voice: (573)882-3477	Voice: (573) 882-3509	Voice: (573) 882-2140
	Fax: (573) 882-1516	Fax:(573) 882-1516
Email: murrayjs@missouri.edu	Email: cullenc@missouri.edu	Email: bickforde@missouri.edu

Mailing address

203 S. 9th St.

Columbia, MO 65211

ADA Accessibility

Wheelchair access to the auditorium is through the north facing side door. Jesse Hall has wheelchair access to the basement at the south entrance and connects to the auditorium via an elevator. There is limited handicap parking close to the theater with additional handicap spaces in nearby parking garages. Handicap seating is available at the front and rear of the auditorium and in the balcony. For additional information please see the campus accessibility map located at <http://accessibilitymap.missouri.edu/>.

Emergency Information

For Fire and other emergency situations call **911**.

University Police
Non-emergency line: 573-882-7201
901 Virginia Ave, Columbia, MO 65211

University Hospital Urgent Care Clinic
Hours: M-F, 8 am- 7:30 pm; Sa-Su, 8 am- 5 pm
Phone: (573) 882-1662

University Physicians Medical Building
1101 Hospital Drive, Columbia, MO 65211

University Hospital Emergency Room - Open 24 hours

Phone: (573) 882-8091
1 Hospital Drive, Columbia, MO 65211
Ambulance Service: (573) 882-6128 or 911

Travel Directions/Parking

Please see Appendix G or our website. Contact us for up to date information. Columbia, MO is in the Central Time Zone.

<http://www.concertseries.org/>

**Jesse Auditorium
University of Missouri**

Management

Production Office

A small production office suitable for one person is available close to stage right and up ½ flight of stairs. Two wired phone lines, one fax line and an RJ-45 Ethernet port for internet access are available in this office. Password protected 802.11b Wi-Fi is available.

Production office phones:

Phone #1	(573) 882-3061
Phone #2	(573) 884-7740

Crew

Jesse Auditorium is a non-union hall. We have a well-trained house crew that is a mix of students and professionals. There is a 2 hour minimum call.

ADA Accessibility

Wheelchair access to the stage is through the Stage Doors USL and USR or via a lift from the auditorium floor. There is one ADA accessible star dressing room with private lavatory located downstage left.

Wheelchair access to the auditorium is through the north facing side door. Jesse Hall has wheelchair access to the basement at the south entrance and connects to the auditorium via an elevator. There is limited handicap parking close to the theater with additional handicap spaces in nearby parking garages. Handicap seating is available at the front and rear of the auditorium and in the balcony. For additional information please see the campus accessibility map located at <http://accessibilitymap.missouri.edu/>.

Policies

Typically the house opens 30 minutes prior to curtain. Normal curtain time is 7:00 pm. Building is a non-smoking building.

Load in Area

Load in door is 8' (2.43m) x 10'-9" (3.3m) with a concrete ramp into the parking lot. Please note that there is no loading dock. Door opens directly into the stage right wing. 2 trucks can be accommodated at once in the parking lot. Theater can provide ramp from lot into door. Trucks may remain parked at load door. Auditorium staff does not control access to parking lot. Please see Appendix G for more information.

**Jesse Auditorium
University of Missouri**

Carpentry

Seating

1,732 seat proscenium theatre (fixed seats: 1000 in orchestra, 732 in balcony). See Appendix D for seating chart. Additional temporary seating is available on the orchestra pit cover. The number of seats does not include seats blocked for production use.

Stage Dimensions

Proscenium opening:	54'10" (16.7m) wide x 20' (6.1m) high
Upstage wall to plaster (on center):	34'-7" (10.4m)
Plaster to downstage lip (on center):	8'-2" (29.6m)
Grid Height	47' (14.3m)
Stage to House floor (vertical):	3'-6" (1.1m)
Orchestra Pit Depth (from house floor):	2'-6" (0.8m)
Stage right wing space (approx.):	15' (4.6m) wide x 22' (6.7m) deep
Stage left wing space (approx.):	13' (4.0m) wide x 25' (7.6m) deep

Wenger stage extension may bring the orchestra pit to stage level creating 8' (2.4m) additional space downstage.

Overhead loading door, 8' (2.4m) wide x 10'-9" (3.3m) high, opens onto the stage right wing.

Stage floor

Stage floor is painted black sprung wood, white oak laid over sleepers on concrete.

Trap: 12'-11" (3.7m) long x 3'-11" (1.2m) wide at center stage. (**Trap is the only freight access to basement and dressing rooms**).

Orchestra Pit: Set 2'-6" (0.8m) below house floor, approximately 50' (15.24m) x 9' (2.74m). Standard configuration is level with house floor using custom cover. Pit may also be set to stage level using custom Wenger Vari-lite risers.

Pre-drilling required for lag screw attachment to stage floor.

House Soft Goods

Grand curtain: red with gold trim with matching valance. Curtain travels on guillotines.

Full Stage: 3 black travelers, 22' (6.7m) x 32' (9.8m) panels, with fullness sewn in.

Legs: 4 sets black legs, 22' (6.7m) x 10' (3m) ea, with fullness sewn in.

Borders: 4 black borders, 8' (2.4m) x 60' (18.3m), with fullness sewn in.

Scrim: 1 black sharkstooth scrim, 23' (7m) x 50' (15.2m) seamless.

Cycs: 1 natural muslin cyc, 50' (15.2m) x 22' (6.7m) seamed.

1 grey vinyl cyc front/rear projection screen, 50' (15.2m) x 22' (6.7m) seamless.

Jesse Auditorium University of Missouri

Line Set Data

Please see Appendix A for House line set schedule.

Grid Height: 47'-0" (14.3m).

Working Height of Battens: trims vary, average high trim is 43' (13.11m), and average low is 4' (1.22m). See line set schedule for specific high trims.

Battens: 28 battens 60' (18.29m) long plus 3 battens 52' (15.85m) long, all are 1 ½" schedule 40 pipe on 8" (20.3 cm) centers with 5 lift lines.

Type: Single purchase counterweight system with 28 lines. 3 upstage lines are double-purchase (see line set schedule).

Arbor Capacity: 760 lbs (345.45 kg) with the following exceptions:

Lines 3, 11, 18, 26 capacity is 490 lbs (222.72 kg)

Lines 29-31 capacity is 800 lbs (363.63kg), these are double purchase lines

A limited number of lead weights are available; using these approximately doubles arbor capacity

Available Weight: 9000 lbs (4090 kg)

Lock Rail and Loading Gallery: Lock rail is 8' (2.44m) above stage left. Loading Gallery is at Grid level stage left. Both are accessed by a spiral staircase located upstage left.

Ladders: Upright 25' (7.62m) AC Personnel Lift, 10' (3m), 8 (2.44m)', 4' (1.22m) ladders.

Notes: Main Curtain and Valance may not be moved from their positions.

The 4 house electrics have a double pipe truss with permanent raceways. The cable picks for these pipes are stage right.

Rigging points unavailable downstage of plaster line.

Rigging points available onstage. Technical Director must approve final locations.

The University does not allow points to be hung from the grid C channel ribbons. Piping the ribbons is also not allowed. All 1 or 2 ton points must rig to the well steel. See Appendix E for details.

**Jesse Auditorium
University of Missouri**

Lighting

Power: Stage right: #1 400A 208VAC 3P 4W (with cams)
#2 400A 208VAC 3P 4W (bare wire tails required)
Stage left: #3 200A 208VAC 3P 4W (with cams) [Sound Power]

Dimmers: Colortran D192 system, installed 1986 (DMX-512 capable)

248 2.4 kW dimmers

12 6.0 kW dimmers

Dimmer per circuit system with soft patch at console, see Appendix B for circuit layout.

Stage pin connectors

Control Board: ETC Obsession II 1500 console v5.1 located center front of balcony

DMX (2 Universes) runs to SL, SR and all onstage Electrics

DMX tie-in located stage right

House lights: House lights may be controlled from console or independently

Front of House Positions: 3rd FOH cove, 59' throw at 43 degrees (main position)

2nd FOH cove, 45' throw at 55 degrees

1st FOH motorized batten, 28' throw at 68 degrees

Balcony Rail, 51' throw at 19 degrees

Over stage Positions: 4 onstage electrics, distance from plaster line 5'3" (1.6m), 12'7" (3.83m),

18'5" (5.62m), 22'6" (6.86m)

2 fixed (DS) and 8 roving booms

Fixture Inventory

- 135 ETC 575W Source 4 ellipsoidals
19, 26, and 36 degree lens tubes available for all
6 50 degree lens tube available
- 48 ETC 575W Source 4 PARs
WFL, MFL, NSP & VNSP lenses available for all.
- 36 Altman 1000W PAR 64 cans
WFL & MFL, limited number of NSP, VNSP.
- 6 Altman 1000W 3 cell Sky-Cyca
- 7 6' 3 color strips with 300W R40 lamps
- 2 Strong Super Trouper 2kw followspots
- 18 Wybron CXI 7.5" Color Scrollers
- 18 Apollo Roto-Q DMX Gobo Rotators

Adequate cable and 2-fers

Work Lights

Effects

- 1 DMX controlled 1000W strobe light
- 4 Chauvet LED Shadow blacklights
- 1 ReelFX DF-50 Hazer
- 2 High End F-100 smoke machines
- 2 Little Blizzard snow machines
- 1 16" (40.6 cm) diameter mirror ball
- 5 10' (3.04m) x 22' (6.7 m) gold rain curtain (slit drape)

**Jesse Auditorium
University of Missouri**

Projection Equipment

- 1 Eiki LC-X800 12000 lumen data projector
- 1 Analog Way Pulse PSL300 switcher
- 1 Pioneer V8000 DVD player
- 1 Mac Mini
- 1 Dell PC
- 1 screen (flown) 50' (16.5m) wide x 22' (6.7m) high.
- 1 Rear projection screen 17' (5.18m) wide x 13' (3.96m) tall
- 1 Rear projection screen 14' (4.3m) wide x 10.5' (3.2m) tall.

**Jesse Auditorium
University of Missouri**

Sound

Power: 200A 208VAC 3P 4W (with cams) located upstage left

Wiring: Please see Appendix C

Control Locations: House mix position is center front of balcony, 52' (15.85m) from stage
Show mix position is 11' (3.35) x 7' (2.13m) located house right of center near the rear of the house. Position is under balcony but has clear line to PA. 125' (38.1m) run to backstage left.

Hearing assist system: Listen 2 VHF FM, 4 units available.

Monitor/ Paging: Dressing room program and paging feed available.

Production Communications:

Clear Com 4 channel system with stations at Sound, Lights, Spots, stage left/right, and back of house.

Equipment Inventory

Mixing Console: 24 channel Soundcraft GB8-24 mixing console with 8 buss and 8 aux.

Fixed Speakers: Flown Meyer M2D line array. (6) M2Ds, (1) UPA-1P & (3) M2DSUBs per side. Feeds to Left, Right and Subs available upstage left. PA installed 2003 (Stereo)

Signal Processor: Meyer Galileo 616

Portable Speakers: (4) EAW JF60s for front fill, (4) DAS DS-15, (4) JBL monitor wedges.

Microphones available:

- (4) Shure SM58
- (1) Shure SM58 with switch
- (6) Shure SM57
- (3) Shure SM98 miniature condenser
- (1) Shure Beta 91
- (4) Audio Technica 4041 condenser
- (2) Audio Technica 4050 large diaphragm condenser
- (2) Audio Technica 3031 condenser
- (1) Audio Technica 815A Shotgun
- (2) Sennheiser MD421 II microphone
- (4) Sennheiser SKM535-G2 wireless handheld w/ MD835 capsule
- (2) Sennheiser SKM500-G2 wireless bodypack MKE2-EW lavalier
- (8) Sennheiser ME-34 (long or short base available)
- (4) Crown PCC-160S
- (1) Crown 12SP PZM
- (1) Crown GLM-100 Wired Lavalier
- (1) Crown CM-311A headworn differoid

Playback: (2) Denon DN-C630 CD players

- (1) Tascam CD-RW900 CD player/burner

Signal Processors: Lexicon LXP 15 II multi-effects processor

- BSS DPR 404 quad compressor/de-esser
- 2 DBX 166XL dual channel gate/compressor/limiter
- 10 EQ channels (4 1/3 octave, 2 parametric, 4 1/3 octave digital)
- Klark Teknik DN 514 auto gate

Other: Adequate XLR cable

Jesse Auditorium University of Missouri

Local RF Usage:

In House Sennheiser Wireless microphones use:

651.150MHz, 652.250MHz, 653.850MHz, 642.950MHz

Wireless Clear Com units' use: 175.400MHz, 206.775MHz, 207.250MHz, 208.150MHz,
208.375MHz, 209.150MHz, 209.425MHz

802.11b equipment is in use in the auditorium. Telephones and other equipment operating around 2.4GHz should not be used.

All your equipment should avoid RF usage near TV channel 8 (180-186MHz). Avoid TV channel 13 (210-216MHz) if possible.

All 802.11b equipment must operate on CH 1 only. Other channels are in use.

**Jesse Auditorium
University of Missouri**

Props

Orchestra Pit: Set 2'6" (0.76m) below house floor, approximately 50' (15.24m) x 9' (2.74m). Standard configuration is level with house floor using custom cover. Pit may also be set to stage level using custom Wenger Vari-lite risers.

Music: Chairs: 120 padded black orchestra chairs, 6 cello chairs, 15 stools.

Music stands: 65 black Wenger Bravo non-folding stands,

Stand lights: 38 stand light plus adequate power stringers

Conductor Podium: Wenger 2 step conductor podium

Piano: No piano in house, Yamaha or Steinway 9' piano available by special arrangement.

Acoustic Shell: White fiberglass on aluminum, sectional back wall, ceiling & wings. Different configurations available

Platforms: (4) StageRight risers with 16"-24" (41-61cm) Z-legs

Dance Floor: Black Marley, will cover approximately 50' (15.24) x 31' (9.45m)

Lecterns: (1) Adjustable height wood lectern with light and University Seal, (1) fixed height wood lectern with light.

Folding tables: Ten 2'-6" x 8'-0" (0.8 x 2.4m) tables, Two 2'-6" x 6' (0.8 x 1.8m) tables.

Wardrobe

Dressing Rooms:

1 ADA accessible star dressing room with private lavatory located close to stage left.

1 small dressing room without private lavatory located close to stage right up a half level.

2 chorus dressing rooms with running water, mirrors, costume racks & lights, capacity of 20 each, located one flight down from stage.

Showers and toilets are across the hall from chorus rooms.

Please note that there is not a green room.

Equipment Inventory:

Laundry room with full size washer and dryer

1 double sided costume rack

4 single rail costume racks

Hangers available

3 ironing boards

4 irons

2 steamers

Notes: Stage trap is the only freight access to the basement dressing room area. Any cases that need to go to the dressing rooms must be flown through the trap.

**Jesse Auditorium
University of Missouri**

Appendices

- A. Line Set Schedule
- B. Lighting Circuit Layout
- C. Sound Input Layout
- D. Seating Chart
- E. Auditorium Drawings
- F. Auditorium Photos
- G. Driving Directions, Maps
- H. Local Amenities

**Jesse Auditorium
University of Missouri**

Appendix A: Line Set Schedule

#	*Arbor Capacity	Distance from Plaster Line	Show Hang	Pipe Length	Max Height	Notes-with weight in pounds
		0' -1'	Fire Curtain			Fire Curtain
1	490 lbs	1' 6"	Main Teaser			Main Teaser
2	760 lbs	2'	Main Curtain			Main Curtain
3	490 lbs	3' 3"		57' 2"	44' 11"	
4	760 lbs	4' 2"		62' 3"	42' 11"	
5	780 lbs	5' 3"		60' 1"	39' 9"	First Electric
6	760 lbs	6' 1"		63'	41' 8"	
7	760 lbs	6' 7"		62' 10"	41' 9"	
8	760 lbs	7' 6"		62' 9"	41' 4"	
9	760 lbs	8' 3"		63'	42' 2"	
10	760 lbs	8' 8"		63'	43' 9"	
11	490 lbs	9' 4"		61' 7"	43' 10"	Border (88)
12	760 lbs	10' 1"		63'	42' 11"	First Traveler (530)
13	760 lbs	10' 7"		62' 11"	43' 3"	
14	760 lbs	11' 7"		63'	42'	
15	780 lbs	12' 7"		59' 7"	40' 1"	Second Electric
16	760 lbs	13' 7"		63'	43' 2"	
17	760 lbs	14' 4"		62' 11"	42' 2"	
18	490 lbs	15' 6"		62' 1"	44' 2"	Border (88)
19	760 lbs	16' 8"		62' 9"	42' 10"	Second Traveler (530)
20	760 lbs	17' 5"		62' 11"	43' 7"	
21	780 lbs	18' 5"		60'	40' 3"	Third Electric
22	760 lbs	19' 7"		62' 9"	41' 11"	
23	760 lbs	20' 7"		62' 9"	42' 9"	Border (88)
24	760 lbs	21' 7"		62' 9"	43'	
25	780 lbs	22' 6"		59' 4"	40' 4"	Fourth Electric
26	490 lbs	24' 5"		62' 9"	45' 4"	
27	760 lbs	25' 6"		62' 11"	43' 5"	Third Traveler (530)
28	760 lbs	26' 3"		62' 1"	42' 2"	
29	800 lbs	30' 1"		52'	45' 6"	Double Purchase
30	800 lbs	30' 9"		52'	45' 6"	Double Purchase
31	800 lbs	31' 4"		52'	45' 6"	Double Purchase

* Limited number of lead weights available. Weight capacity is increased approximately 2x using lead weights.

Grid height = 47' 0"

<http://www.concertseries.org/>

**Jesse Auditorium
University of Missouri**

Appendix B: Lighting Circuit Layout

**Jesse Auditorium
Circuits Layout**

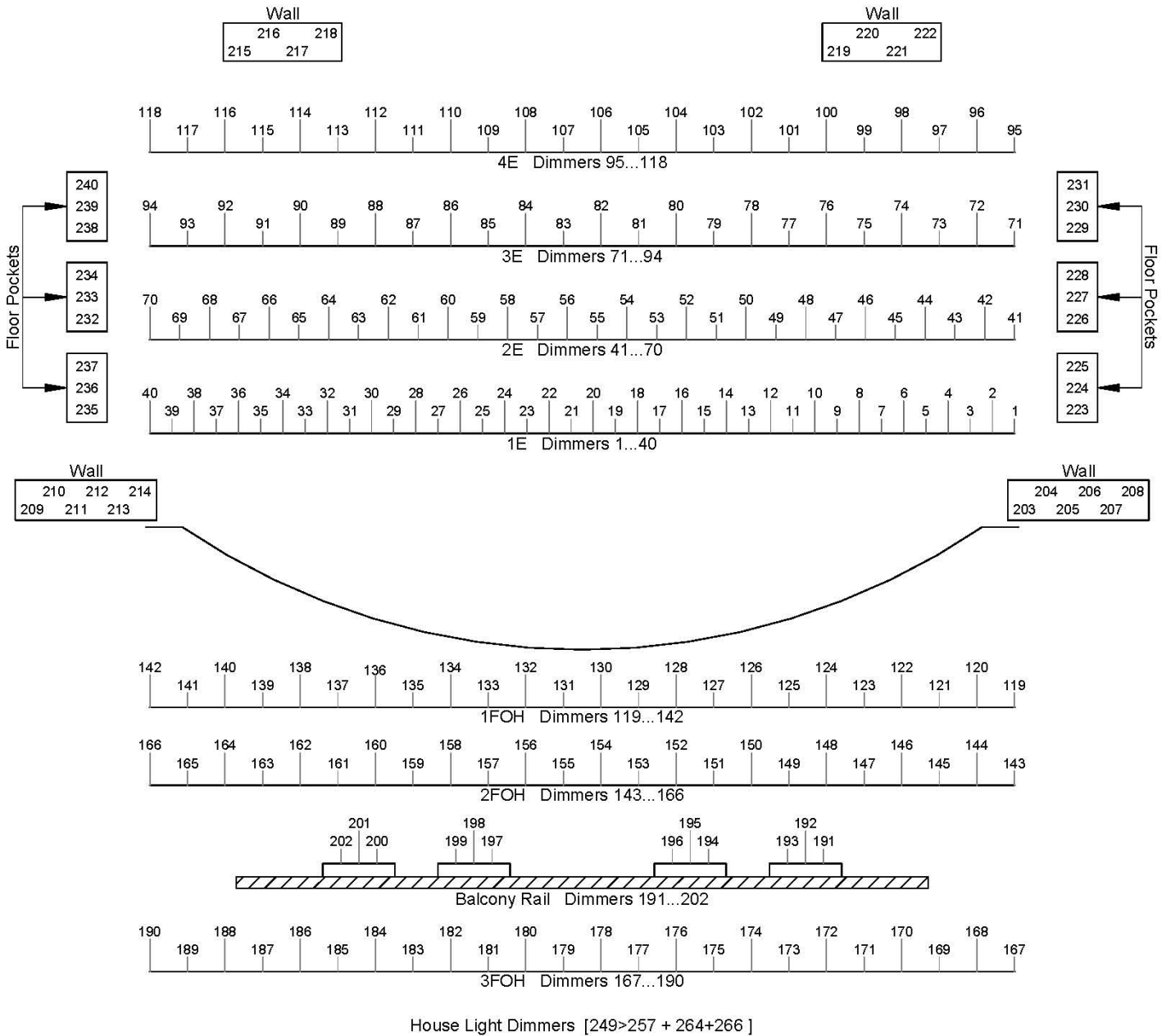

<http://www.concertseries.org/>

Jesse Auditorium
University of Missouri

Appendix C: Sound Input Layout

Jesse Auditorium
Sound Layout

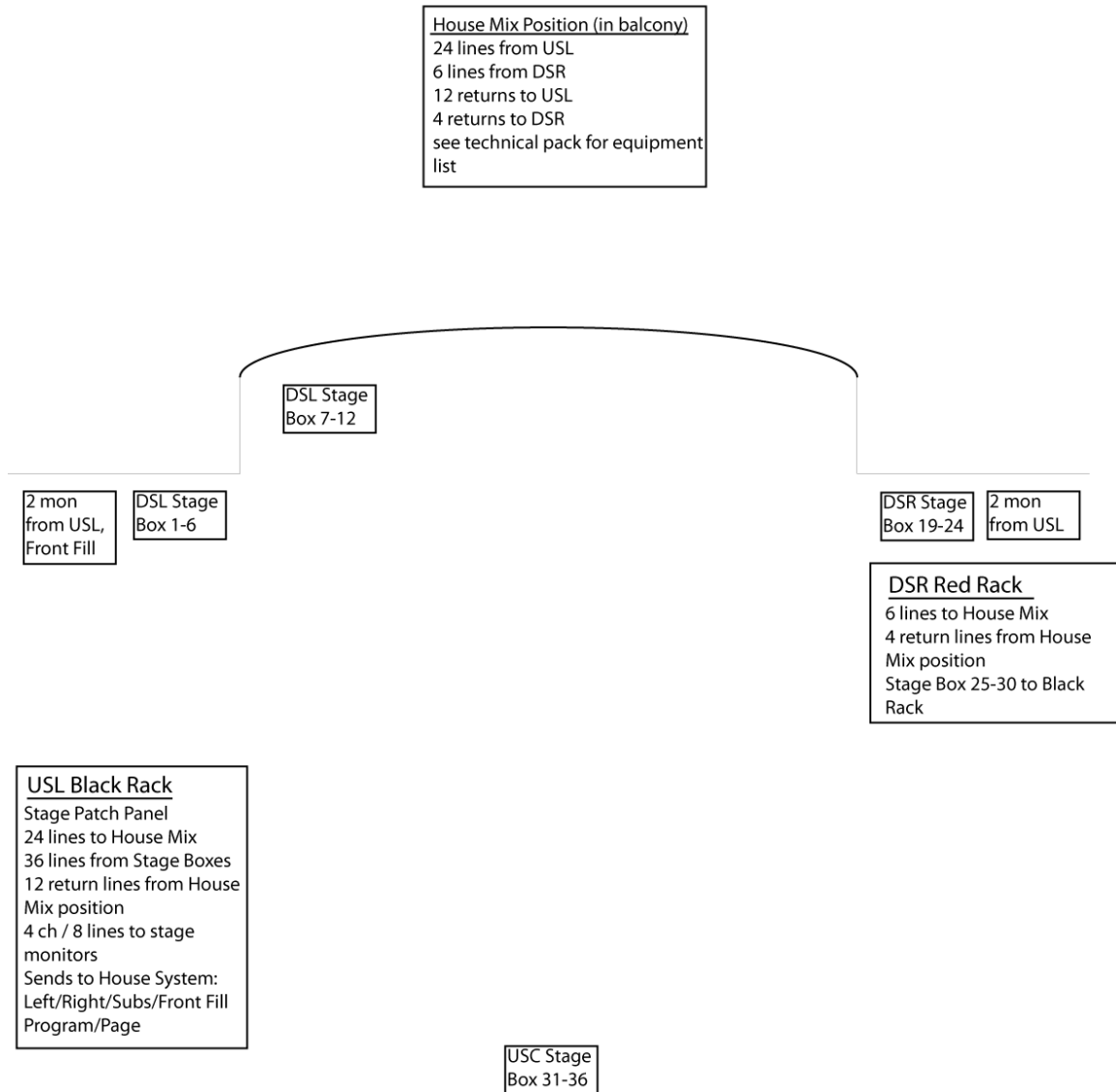

Jesse Auditorium University of Missouri

Appendix D: Seating Chart

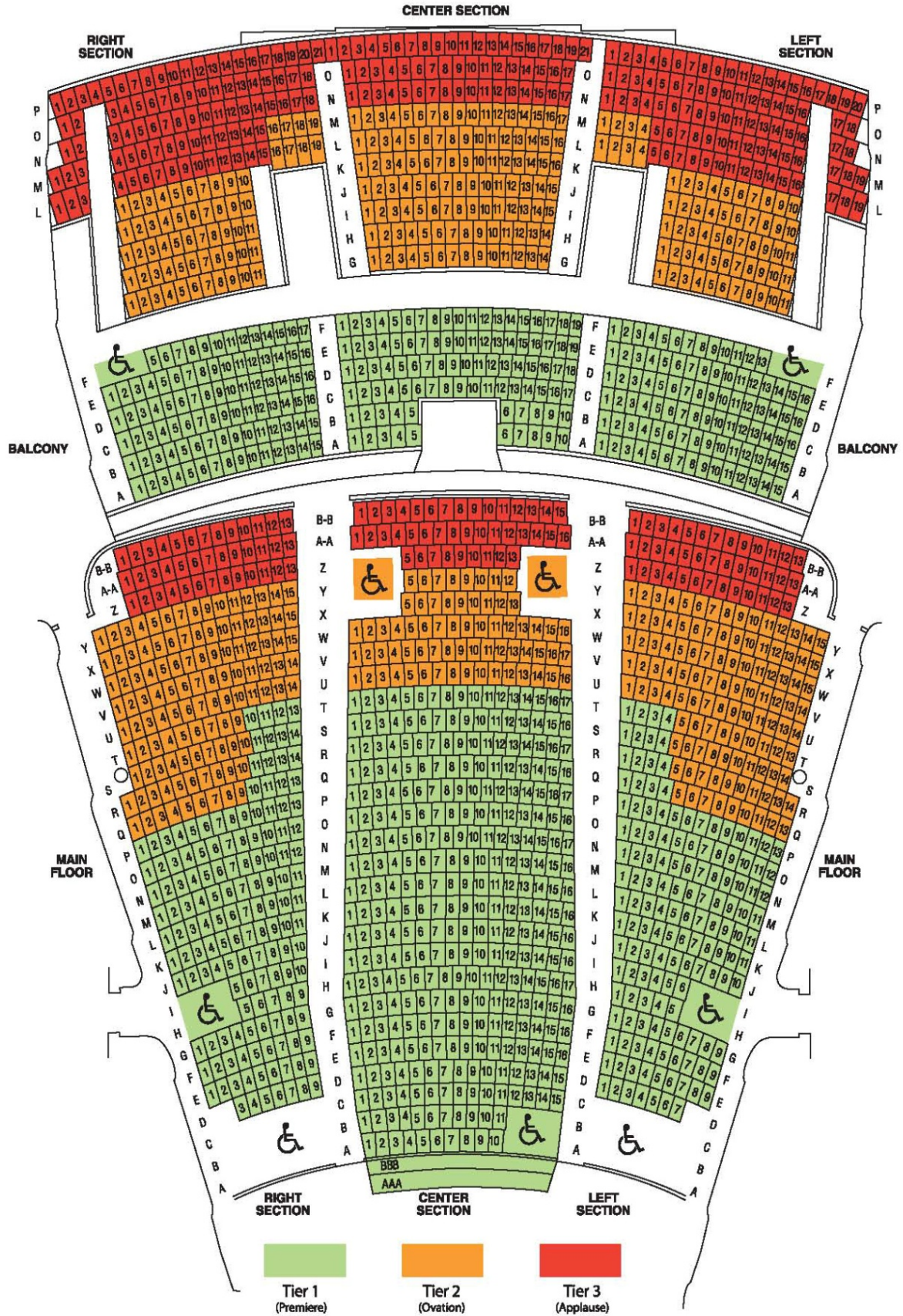

Jesse Auditorium University of Missouri

Appendix E: Auditorium Drawings

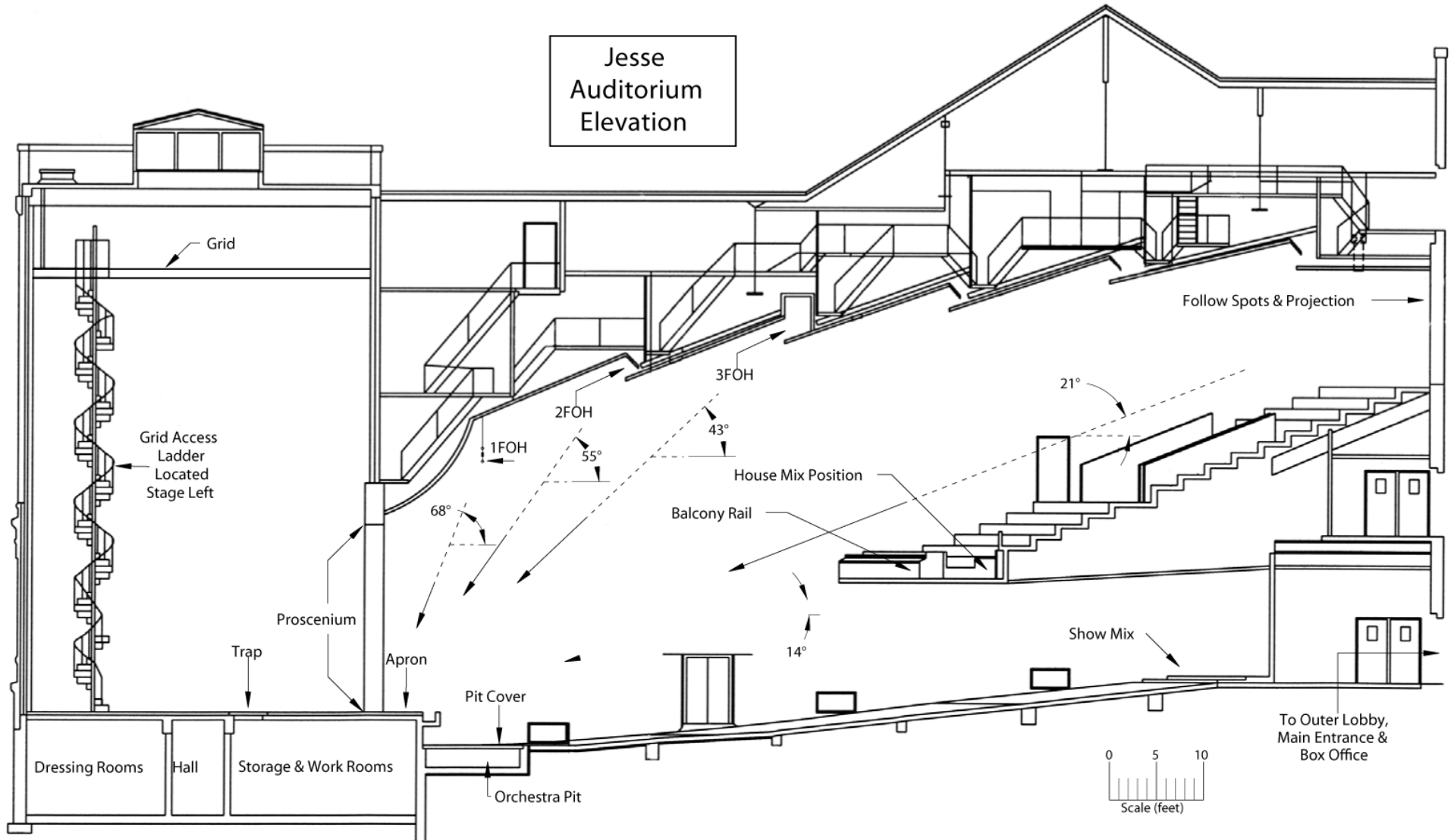

Jesse Auditorium
University of Missouri

Jesse Auditorium Grid Steel Layout

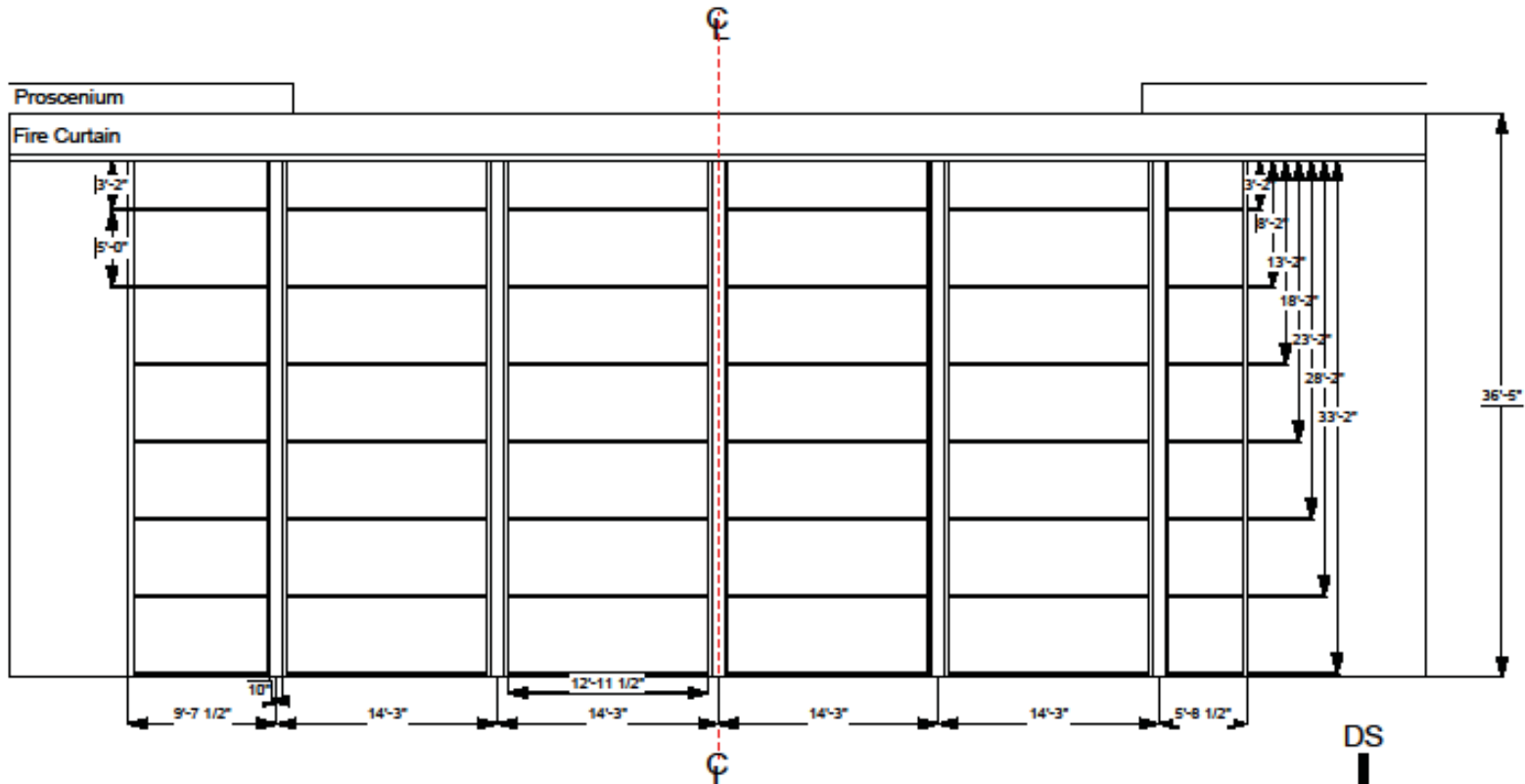

US/DS Well Steel Girders
SR/SL Steel

Rated at 2000 lbs per point
Rated at 700 lbs per point

Proscenium Opening 54' 10"
Proscenium Height 20'
Grid Height 47'
Average Batten Clearance 42'

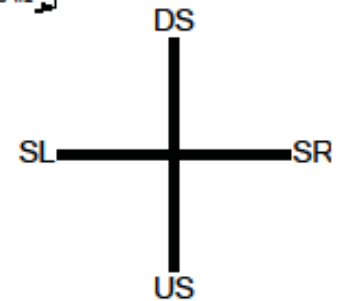

<http://www.concertseries.org/>

Jesse Auditorium Bridle Sheet

All distances rounded to 6"
All bridles with 5' basket

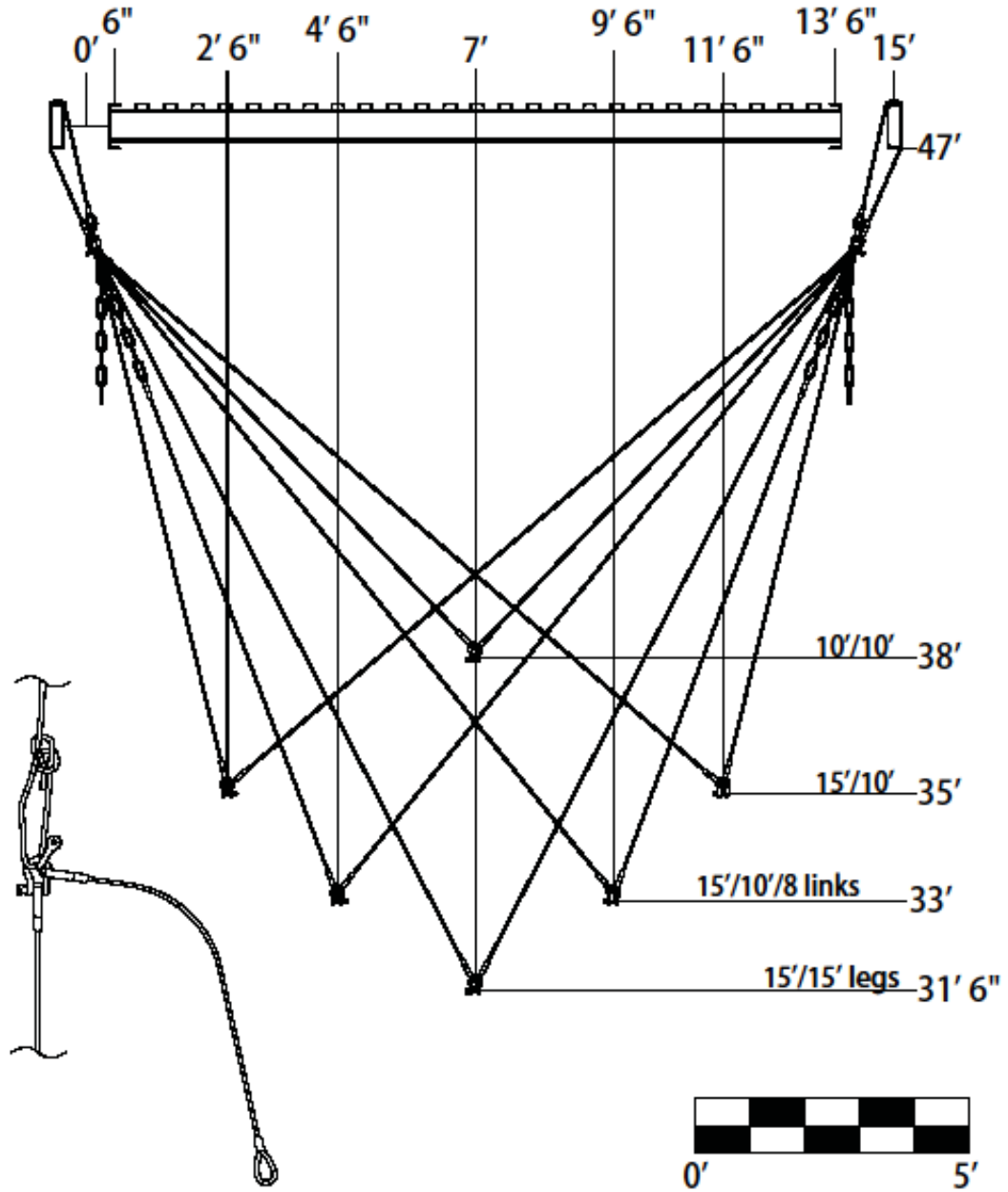

Jesse Auditorium

Basic Stage Layout & Dimensions

Note: Some wing measurements are approximated for simplicity.

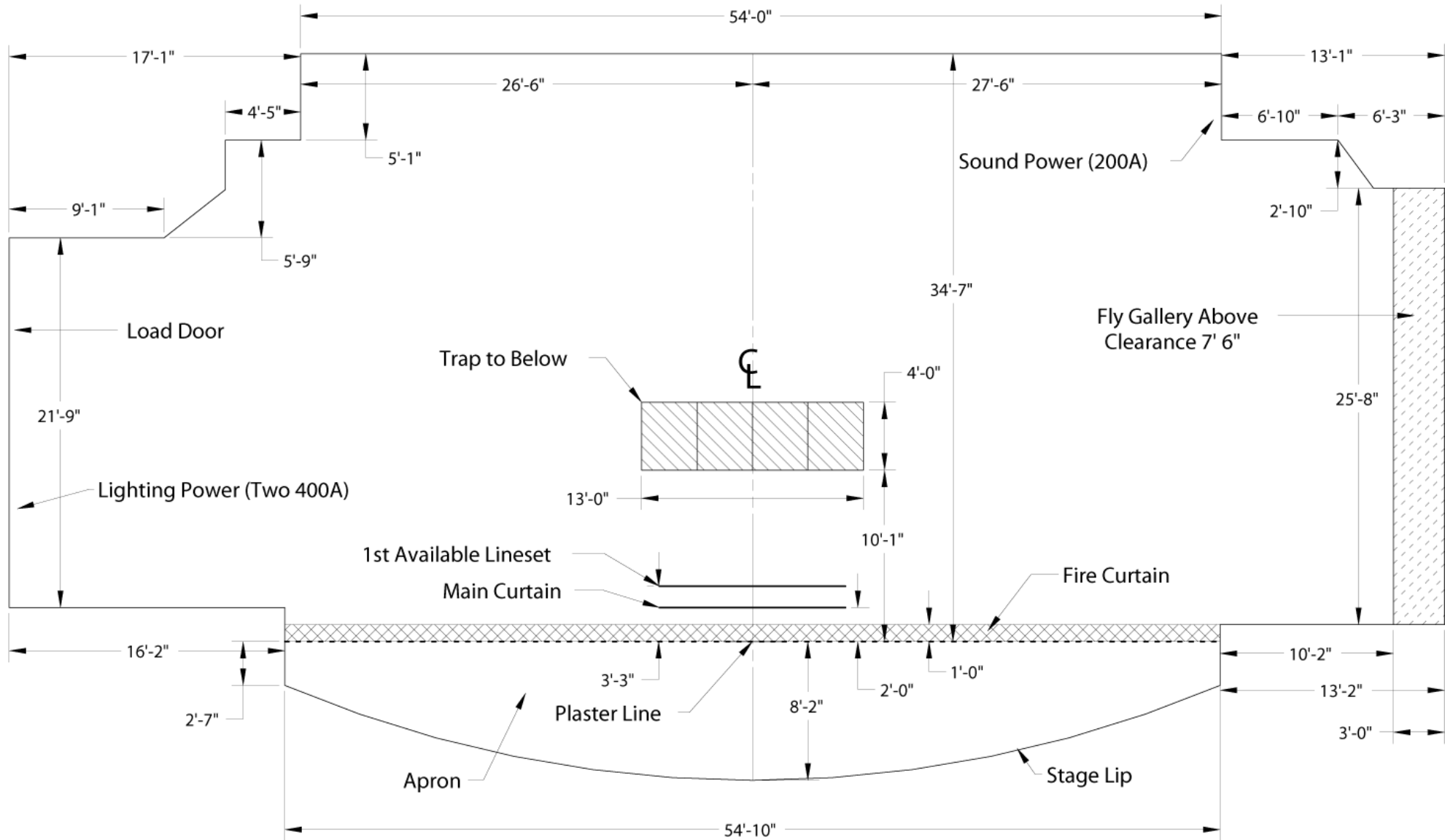

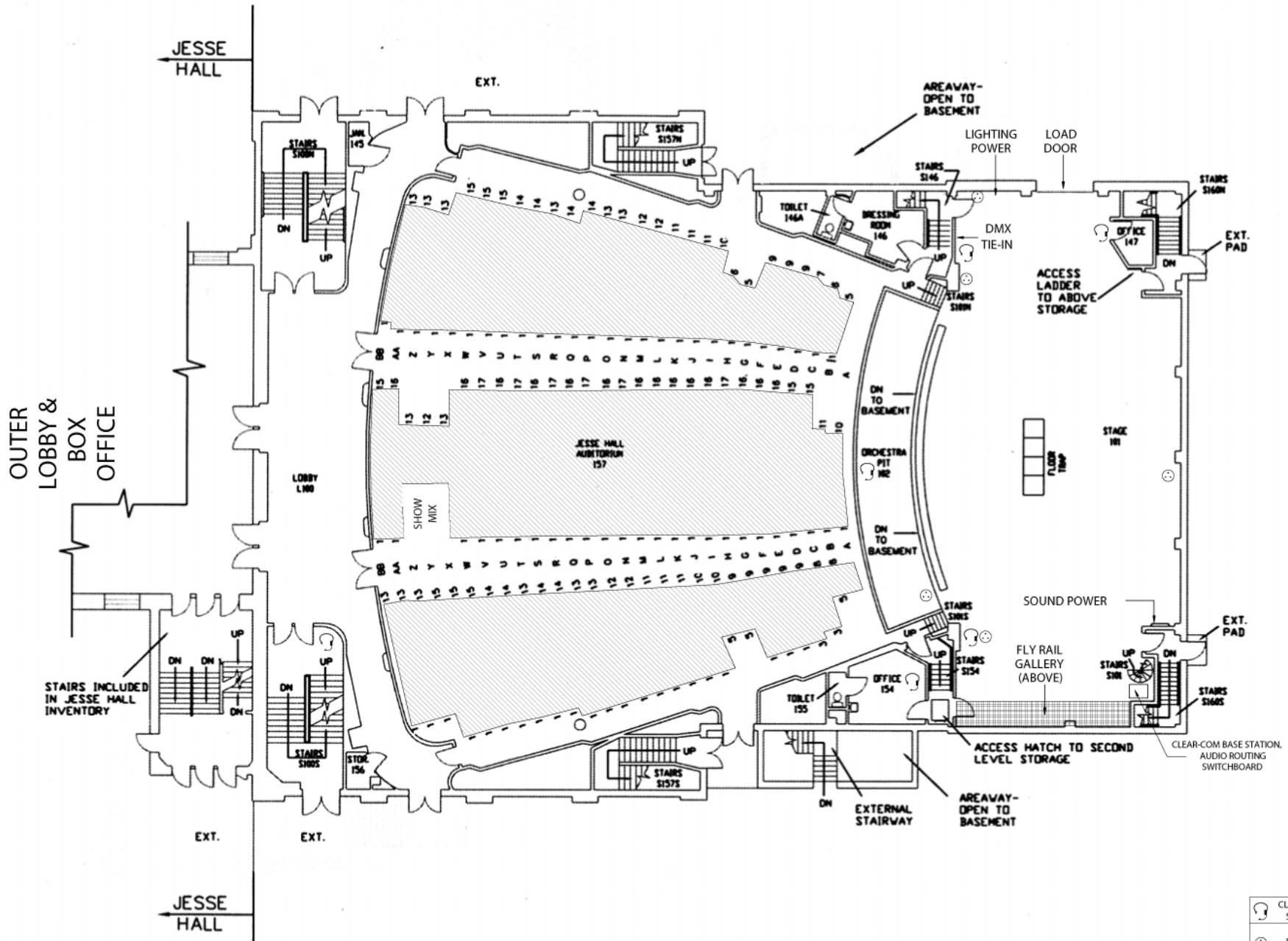

 CLEAR-COM STATION
 AUDIO ROUTING ACCESS

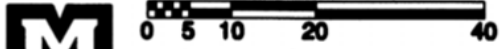

SPACE PLANNING & MANAGEMENT
 CAMPUS FACILITIES (573) 882-4506

JESSE HALL AUDITORIUM

LEVEL: FIRST BUILDING NO: 37243	TOUR DATE: 04-16-98 SHEET: 2 OF 5	SCALE: TO FIT GROSS SQ FT: 15,082	 NORTH
---	--	--	---

REVISED: 06-09-98

**Jesse Auditorium
University of Missouri**

Appendix F: Auditorium photos



View of the loading door from the street



View of the loading area outside the Load Door

<http://www.concertseries.org/>

**Jesse Auditorium
University of Missouri**



View of the loading area from inside

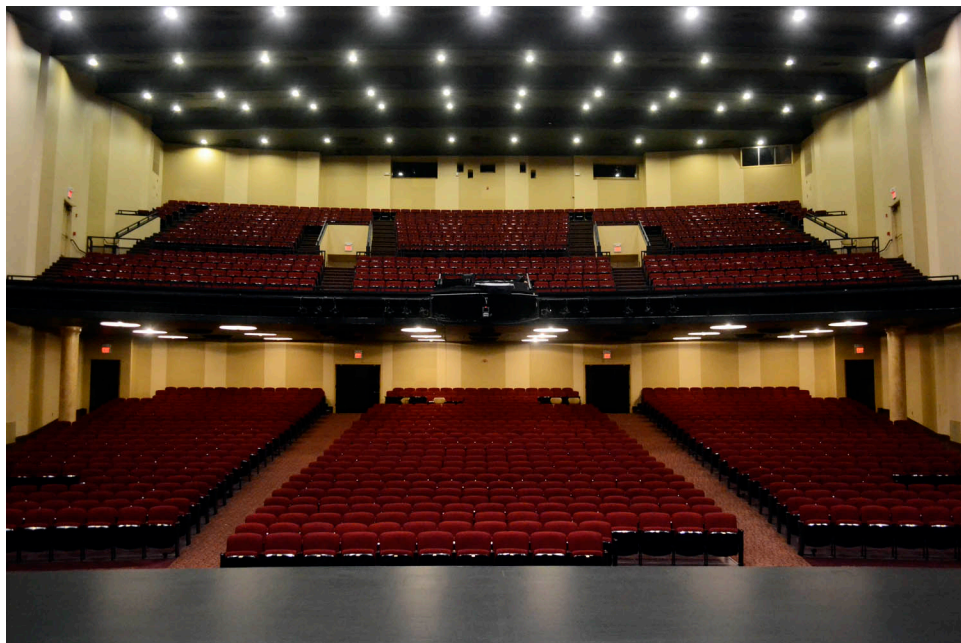

View of the house from the stage

<http://www.concertseries.org/>

**Jesse Auditorium
University of Missouri**



View of the stage from the house

<http://www.concertseries.org/>

**Jesse Auditorium
University of Missouri**

Appendix G: Driving Directions/ Maps

Directions to Jesse Auditorium, Columbia, MO.

The University does not utilize street addresses. The auditorium is attached to Jesse Hall on the University of Missouri campus. This address will get you to the top of our driveway in most mapping software;
521 South 9th Street
Columbia, MO. 65201

Our loading situation is not ideal but can be managed. There is no loading dock. Once the truck(s) are in place in the parking lot they can stay there. There is room for 2 trucks in the lot.

If arriving before 8:15am on Monday - Friday with the truck(s)

Driving West or East on I-70
Exit Providence Rd (163) South (Exit # 126). – Go 1.2 miles
Left (East) on Broadway
Right (South) on 6th St
Left (East) on Conley Ave - 6th St dead ends into Conley
Follow Conley Ave ¼ mile and it will the bend 90 degrees to the left and become 9th St
Jesse Auditorium is 2nd building from corner of 9th & Conley on the left.
The 1st driveway on the left leads to loading door
Trucks must back down to load door and can only do this while facing North on 9th St.

If arriving after 8:15am on Monday - Friday with the truck(s)

(The university closes the intersection of 9th St. and Conley Ave. at 8:15am to 3:45pm)
Driving East or West on I-70
Exit US 63 South (Exit # 128A). Go south
Drive approx. 1mile
Exit onto E. Broadway. (right turn (west) onto Broadway)
Drive approx. 1-3/4 mile
Left turn (south) onto College Ave
Drive approx. 1/3 mile
Turn right (west) onto University Ave
Drive approx. ½ mile until University dead ends into 9th St.
Here's the problem part
Trucks must back down to load door and can only do this while facing North on 9th St.
Turn right (north) on 9th St.
Once turned and facing north then the truck has to back up about 100 yards to our driveway
Jesse Auditorium is the 1st driveway on right (west side) after crossing University Ave.

Jesse Auditorium University of Missouri

Directions for Buses only

Driving West or East on I-70

Exit Providence Rd (163) South (Exit # 126). – Go 1.2 miles

Left (East) on Broadway

Right (South) on 9th St

Drive 4 blocks

You will be at the intersection of 9th street and University Ave. Proceed 100 yards straight thru that intersection.

The 1st driveway on the right leads to Jesse Auditorium loading door.

Buses should park on the west side of 9th street at the top of the stairs which are just past the driveway. The stage door is at the bottom of these stairs.

For buses;

Beware very few buses can make it down this driveway due to the steep angle over the sidewalk. Most buses bottom out.

Directions for cars

Driving West or East on I-70

Exit Providence Rd (163) South (Exit # 126). – Go 1.2 miles

Left (East) on Broadway

Right (South) on 9th St

Drive 4 blocks to University Ave. (Dominos Pizza on corner)

Drive straight thru this intersection on 9th St. for 75 yards

The 1st driveway on the right leads to Jesse Auditorium.

You will see our loading door from the street

Parking at the auditorium is extremely limited. There are several parking garages within easy walking distance.

Saturdays and Sundays there are no road closures except construction closures

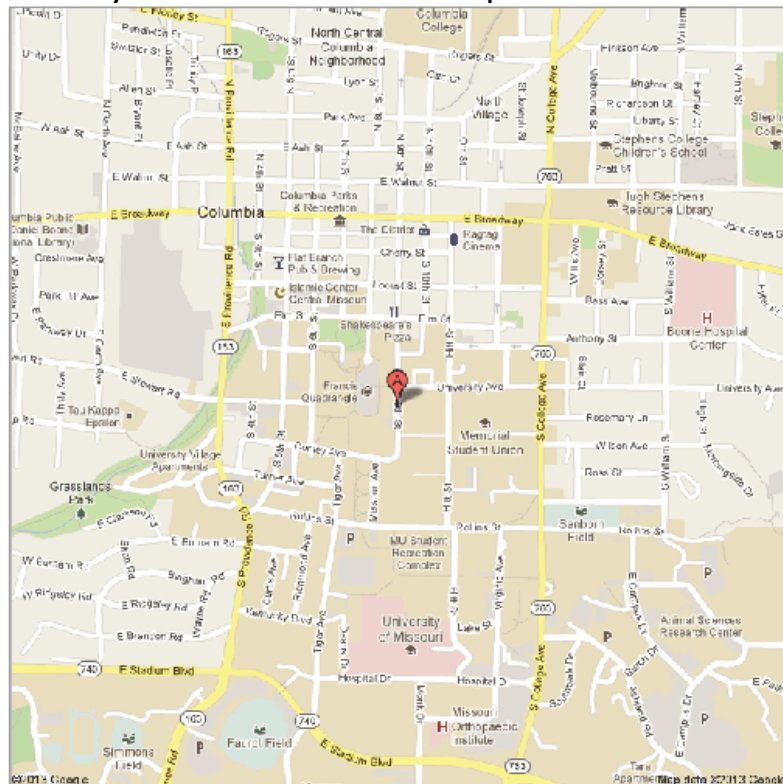

<http://www.concertseries.org/>